

8	7	6	5	4	3	2	1
Material Code	specification 747.7×442.3×9.5mm-V1.0			LOGO	REV.	Date	Changes
				△			
				△			
				△			

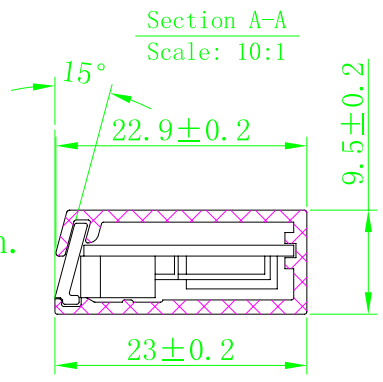
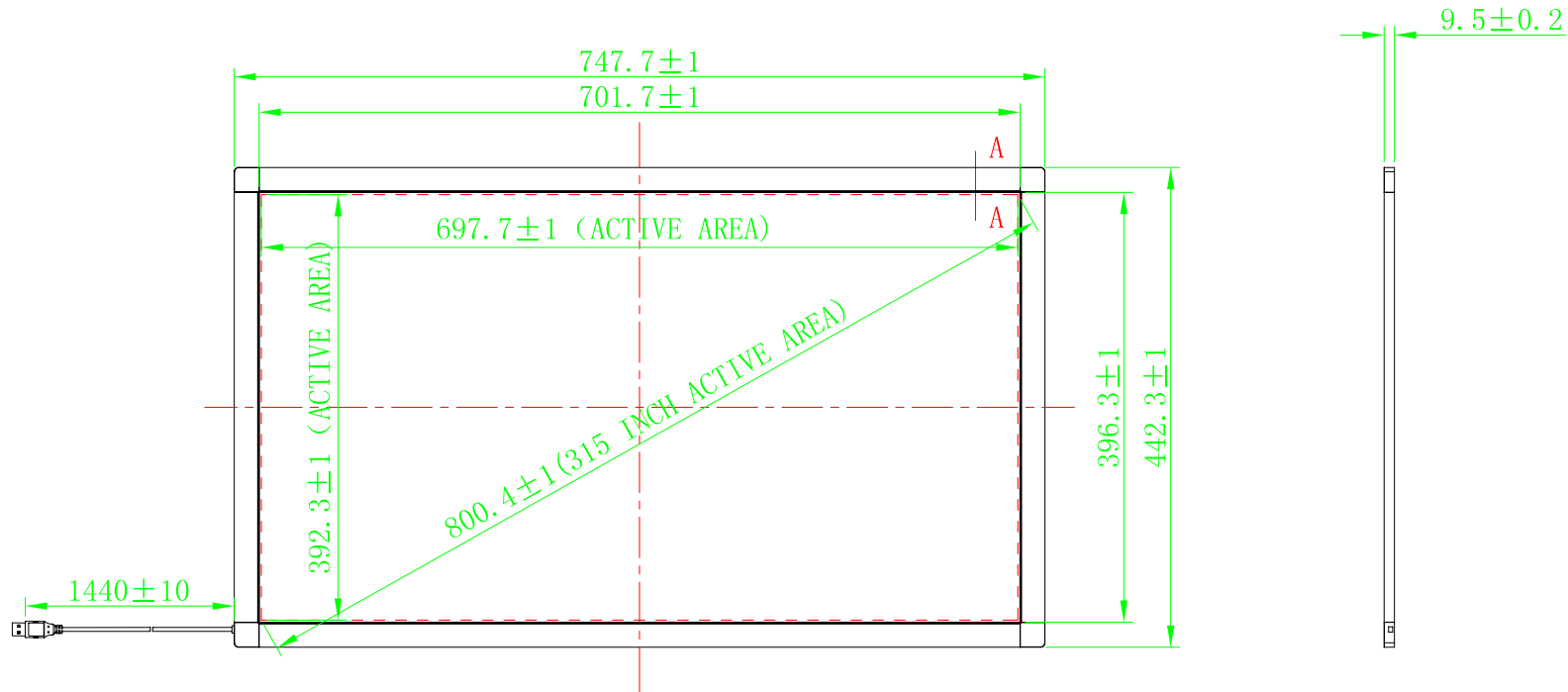

Remarks:
1. Reference design: AU Screen.
2. The product is without the glass.

TOLERANCES
(UNLESS OTHERWISE STATED)

DECIMALS	ANGLES	±0.5°
>2000mm	±2.00mm	
1600 < X ≤ 2000mm	±1.20mm	
1200 < X ≤ 1600mm	±0.80mm	
800 < X ≤ 1200mm	±0.50mm	
400 < X ≤ 800mm	±0.40mm	
120 < X ≤ 400mm	±0.30mm	
30 < X ≤ 120mm	±0.20mm	
≤ 30mm	±0.10mm	

THIRD ANGLE PROJECTION

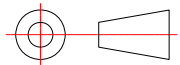

GreenTouch®

MODEL NO.	GT-IR-F32A			NOTES:
PART No.	F315WH00U-01-00-M001	SCALE	1:1	
PART NAME	Product structure diagram	REV.	1.0	
UNIT	mm	SIZE	FREE	
MATERIAL		SHEET	1/1	
DRAWN			CHK' D	
CHK' D			APP' D	